



---

## ABS submersible wastewater pump AS 0530 - 0841

---

1006-00

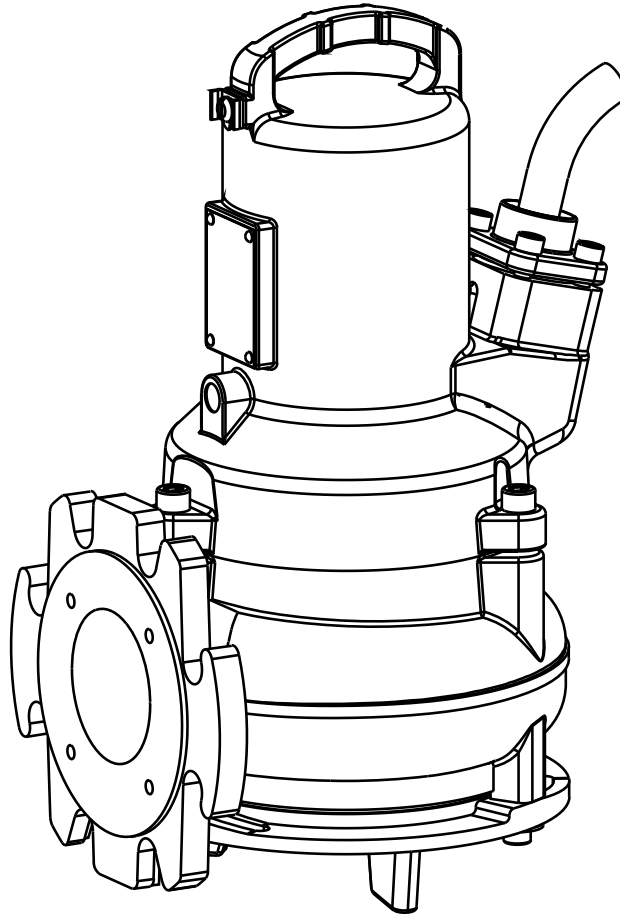

15975045GB (01/2011)

---

**GB** Installation, Operating and Maintenance Instructions

---

[www.cardo.com](http://www.cardo.com)

## ABS submersible wastewater pump AS

0530	0631	0830	0840
0630	0641	0831	0841

## Contents

<b>1</b>	<b>Application areas</b> .....	<b>3</b>
1.1	Approvals .....	3
1.2	Explosion-proof approvals.....	3
<b>2</b>	<b>Safety</b> .....	<b>3</b>
2.1	Particular comments on the use of explosion-proof pumps in explosive zones.....	3
2.2	Special conditions for safe use of S-type, explosion-proof motors. ....	3
<b>3</b>	<b>Technical data</b> .....	<b>4</b>
3.1	Nameplate.....	4
<b>4</b>	<b>Transport</b> .....	<b>5</b>
<b>5</b>	<b>Set-up and installation</b> .....	<b>5</b>
5.1	Discharge line .....	5
5.2	Installation example, concrete sump.....	5
5.3	Electrical connection .....	6
5.3.1	Wiring diagrams .....	7
5.4	Checking direction of rotation.....	8
5.4.1	Changing direction of rotation .....	8
<b>6</b>	<b>Commissioning</b> .....	<b>9</b>
<b>7</b>	<b>Maintenance</b> .....	<b>9</b>
7.1	General maintenance hints .....	10
7.2	Commentary on maintenance of lifting stations in accordance with EN 12056. ....	10
7.3	Oil filling and oil changing .....	11
7.4	Cleaning .....	11
7.5	Venting of the volute.....	11
	<b>EC Declaration of Conformity</b> .....	<b>12</b>

## 1 Application areas

The ABS submersible sewage pumps of the AS series have been designed for the economical and reliable pumping of commercial, industrial and municipal sewage and can be installed dry or wet. They are suitable for pumping of the following liquids:

- clear and wastewater, for sewage containing solids and fibrous material
- faecal matter

The AS series is suitable for modern sewage installation systems.

**ATTENTION**     *The maximum allowable temperature of the medium pumped is 40 °C.*

### 1.1 Approvals

The motors of the AS series have explosion-proof certification in accordance with Factory Mutual Class 1 Div. 1 Groups C and D.

Electrical safety of the AS series are UL and CSA approved.

The motors of the AS series are UL and CSA approved when not FM approved.

### 1.2 Explosion-proof approvals

The motors of the AS series have explosion-proof certification in accordance with Ex d II BT4, ATEX 94/9/EC and FM (60 Hz, US).

## 2 Safety

The general and specific health and safety guidelines are described in detail in the ABS Products Safety Instructions booklet. If anything is not clear or you have any questions as to safety make certain to contact the manufacturer ABS.

### 2.1 Particular comments on the use of explosion-proof pumps in explosive zones.

1. Explosion-proof submersible pumps may only be operated with the thermal sensing system connected.
2. If ball type float switches are used, these must be connected to an intrinsically safe electrical circuit "Protection type EX (i)" in accordance with VDE 0165.
3. Dismantling and repair of submersible explosion-proof motors may only be carried out by approved personnel in specially approved work shops.

### 2.2 Special conditions for safe use of S-type, explosion-proof motors.

1. The integral supply cable shall be suitably protected from mechanical damage and terminated within an appropriate termination facility.
2. Pump motors rated for use with 50/60 Hz sinusoidal supplies shall have the thermal protection devices connected in such a way that the machine is isolated from the supply in the event of the stator reaching 130 °C.
3. Pump motors rated for use with variable frequency or non-sinusoidal supplies shall have the thermal protection devices connected in such a way that the machine is isolated from the supply in the event of the stator reaching 100 °C for T4 classified machines, or 160 °C for T3 classified machines.
4. These motor units are not intended for user service or repair, any operation that may affect the explosion protection characteristics should be referred to the manufacturer. The maximum permitted flame path gaps are tighter than those specified in EN 50018.



### 3 Technical data

Maximum noise level ≤ 70 dB. This may be exceeded in certain circumstances.

Detailed technical information is available in the technical data sheet ABS submersible wastewater pump AS 0530 - 0841 which can be downloaded from [www.absgroup.com](http://www.absgroup.com) > Downloads.

#### 3.1 Nameplate

We recommend that you record the data from the original nameplate on the nameplate illustration below and maintain it, together with your purchase receipt, as a proof for subsequent use.

Always state the pump type, item no. and serial no. in the field “Nr” in all communications

Figure 1 Nameplate Ex Version

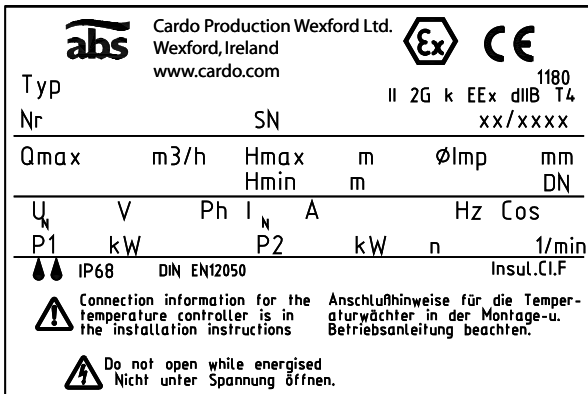

Nameplate Standard Version

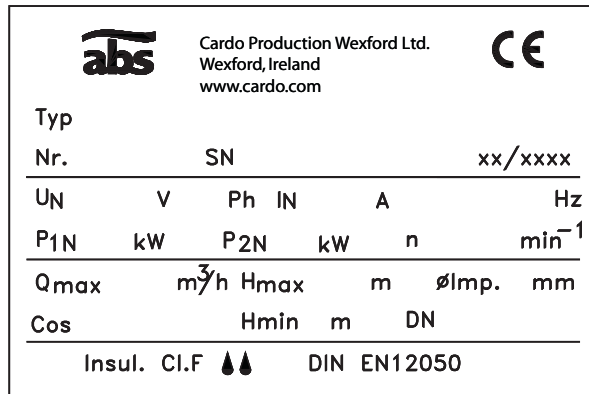

Legend

Type	Pump type
Nr./SN	Item No./Serial No.
xx/xxxx	Production date (Week/Year)
UN	Rated Voltage V
IN	Rated Current A
Hz	Frequency Hz
P1N	Rated Input Power kW

P2N	Rated Output Power	kW
n	Speed	r/min
Qmax	Max. Flow	m <sup>3</sup> /h
Hmax	Max. Head	m
∅ Imp.	Impeller diameter	mm
DN	Discharge diameter	mm

Figure 2 Nameplate FM Version

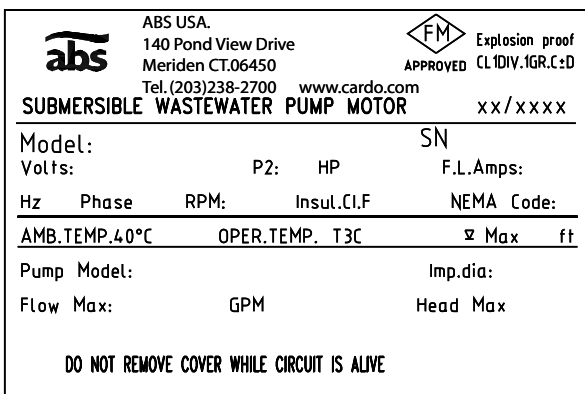

Nameplate Standard Version

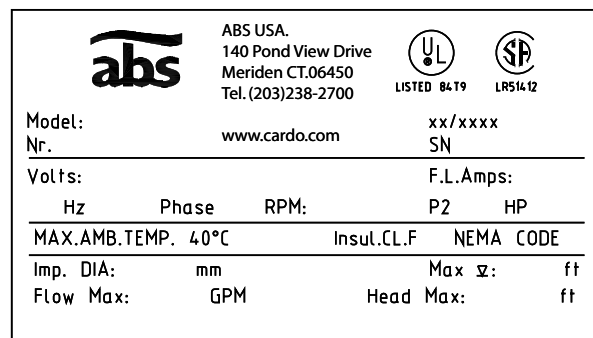

Legend

Model	Pump type/ Item No.
SN	Serial No.
Volts	Rated Voltage V
P2	Rated Output Power HP
F.L.Amps	Full Load Amps A
Hz	Frequency

Phase	Three/Single Phase
RPM	Speed rpm
Imp. dia	Impeller diameter mm
Max. ∇	Max submersible depth Ft
Flow Max.	Rated Discharge GPM
Head Max.	Max. Head Ft

## 4 Transport



During transport the unit should not be dropped or thrown.



The unit should never be raised or lowered by the Power cable.

The unit is fitted with a lifting device to which a chain and shackle may be attached for transport purposes.



Any hoist used must be adequately dimensioned for the weight of the unit.

All relevant safety regulators as well as general good technical practice must be complied with.

## 5 Set-up and installation

**ATTENTION** *All relevant regulations covering sewage pumping installations and, where applicable, explosion-proof installations must be complied with.*



The cable duct to the control panel should be made gas-tight by filling with foam after the power supply and control circuit cables have been laid.



Particular attention must be paid to the safety regulations covering work in closed areas in sewage plants as well as good general technical practices .

### 5.1 Discharge line

The discharge line must be installed in compliance with the relevant regulations. DIN 1986/100 and EN 12056 applies in particular to the following:

- The discharge line should be fitted with a backwash loop (180° bend) located above the backwash level and should then flow by gravity into the collection line or sewer.
- The discharge line should not be connected to a down pipe.
- No other inflows or discharge lines should be connected to this discharge line.

**ATTENTION** *The discharge line should be installed so that it is not affected by frost.*

### 5.2 Installation example, concrete sump

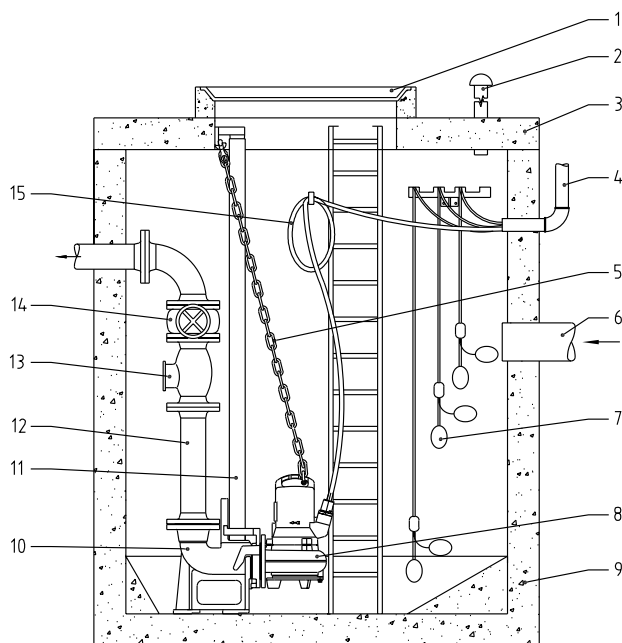

#### Legend

- |    |   |
|----|---|
| 1  | Sump cover  |
| 2  | Venting line  |
| 3  | Sump cover  |
| 4  | Sleeve for cable protective duct to the control panel |
| 5  | Chain   |
| 6  | Inflow line   |
| 7  | Ball type float switch                                |
| 8  | Submersible pump                                      |
| 9  | Concrete sump.  |
| 10 | Pedestal  |
| 11 | Guide tube.   |
| 12 | Discharge line  |
| 13 | Non-return valve                                      |
| 14 | Gate valve  |
| 15 | Power cable to motor                                  |

Figure 3 Installation example, concrete sump

### 5.3 Electrical connection



Before commissioning an expert should check that one of the necessary electrical protective devices is available. Earthing, neutral, earth leakage circuit breakers, etc. must comply with the regulations of the local electricity supply authority and a qualified person should check that these are in perfect order.

**ATTENTION** *The power supply system on site must comply with VDE or other local regulations with regard to cross-sectional area and maximum voltage drop. The voltage stated on the nameplate of the pump must correspond to that of the mains*

The power supply cable must be protected by an adequately dimensioned slow-blow fuse corresponding to the rated power of the pump.



The incoming power supply as well as the connection of the pump itself to the terminals on the control panel must comply with the circuit diagram of the control panel as well as the motor connection diagrams and must be carried out by a qualified person.

All relevant safety regulators as well as general good technical practice must be complied with.

**ATTENTION** *For use in the open air, the following VDE regulations apply:*

Submersible pumps used outdoors must be fitted with a power cable of at least 10 m length. Other regulations may apply in different countries.

For pumps intended to be used in outdoor fountains, garden ponds and similar places, the pump is to be supplied through a residual current device (RCD) having a rated residual operating current not exceeding 30 mA.



**Three phase:** Risk of electrical shock. Do not remove cord and strain relief and do not connect conduit to pump. This pump is not provided with a supply connection, therefore one of the following means must be provided by the installer: (1) A suitably rated, grounding-type attachment plug must be provided for connection to the branch circuit supply, or (2) A listed junction box, listed outlet box, or listed wiring compartment and their associated fittings must be provided by the installer for supply connection. This provision must reduce the likelihood of water entry during temporary, limited submersion. Only qualified personnel shall install the pump.



**Single phase:** Risk of electrical shock. This pump is supplied with a grounding conductor and grounding-type attachment plug. To reduce the risk of electrical shock, be certain that it is connected only to a properly grounded, grounding receptacle, and that the motor is thermally protected. To reduce risk of electrical shock, pull plug before servicing this pump. This pump has not been investigated for use in swimming pools.

**NOTE** *Please consult your electrician.*

### 5.3.1 Wiring diagrams

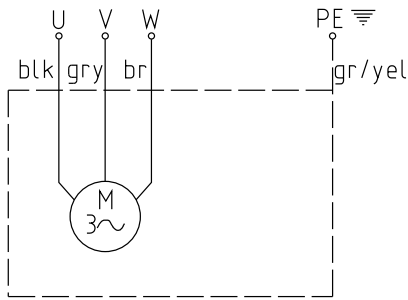

Figure 4 Three Phase Wiring

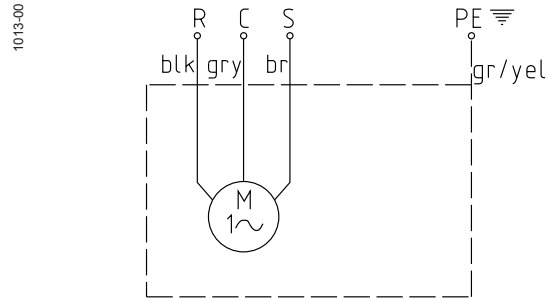

Figure 7 Single Phase Wiring

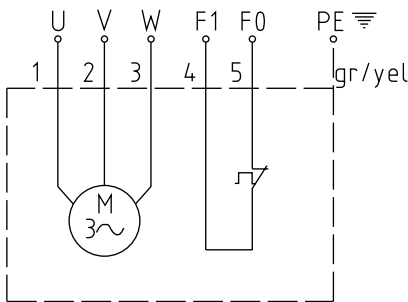

Figure 5 Three Phase Wiring with Temperature Limiter

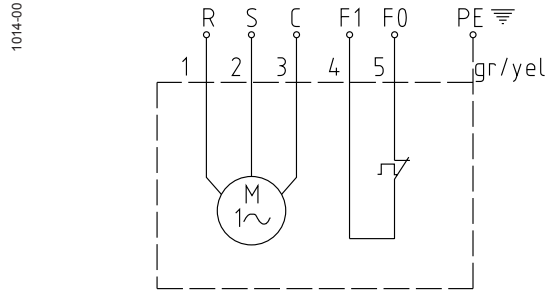

Figure 8 Single Phase Wiring with Temperature Limiter

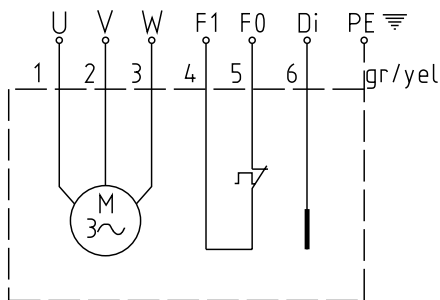

Figure 6 Three Phase Wiring with Temperature Limiter & DI

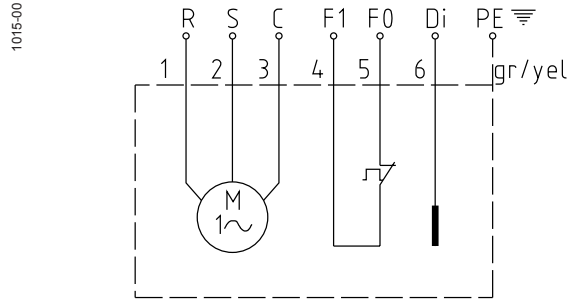

Figure 9 Single Phase Wiring with Temperature Limiter & DI

#### Three Phase

##### AS 50 Hz:

S12/2 D, S13/4 D, S17/2 D, S22/4 D, S26/2 D, S30/2 D,

##### AS 60 Hz:

S10/4 D, S16/2 D, S13/4 D, S16/4 D, S17/2 D, S18/2 D,  
S22/4 D, S25/4 D, S26/2 D, S30/2 D, S35/2 D

#### NOTE:

U, V, W	= Live	Di	= Seal monitor
PE	= Earth	F1/F0	= Thermal sensor
gr/yel	= green/yellow	R	= Run
blk	= black	C	= Common (Neutral)
gry	= grey	S	= Start
br	= brown		

#### Single Phase

##### AS 50 Hz:

S10/4 W, S12/2 W

##### AS 60 Hz:

S10/4 W, S16/2 W, S18/2 W

#### NOTE: USA

U, V, W	= T1, T2, T3
F1	= 1
F0	= 2
Di	= 3

**ATTENTION** *Explosion-proof pumps may only be used in explosive zones with the thermal sensors fitted (Leads: F0, F1).*

**ATTENTION** *It is important to us the correct capacitors with single phase pumps, use of incorrect capacitors will lead to motor burn-out*

#### 5.4 Checking direction of rotation



The safety hints in the previous sections must be observed!

When three phase units are being commissioned for the first time and also when used on a new site, the direction of rotation must be carefully checked by a qualified person.



When checking the direction of rotation, the unit should be secured in such a manner that no danger to personnel is caused by the rotating impeller, or by the resulting air flow. Do not place your hand into the hydraulic system!



The direction of rotation should only be altered by a qualified person.



When carrying out the direction of rotation check as well as when starting the unit pay attention to the **START REACTION**. This can be ver

##### ATTENTION

The direction of rotation is correct if the imeller/propeller rotates in a clockwise manner when viewing down from the top of the placed unit



1020-00

##### ATTENTION

The start reaction is anti clockwise

Figure 10 Rotor rotation

##### NOTE

***If a number of pumps are connected to a single control panel then each unit must be individually checked.***

##### ATTENTION

***The mains supply to the control panel should have a clockwise rotation. If the leads are connected in accordance with the circuit diagram and lead designations, the direction of rotation will be correct.***

#### 5.4.1 Changing direction of rotation



The safety hints in the previous sections must be observed!



The direction of rotation should only be altered by a qualified person.

If the direction of rotation is incorrect then this is altered by changing over two phases of the power supply cable in the control panel. The direction of rotation should then be rechecked

##### NOTE

***The direction of rotation measuring device monitors the direction of rotation of the mains supply or that of an emergency generator***



## 6 Commissioning



The safety hints in the previous sections must be observed!



In explosive zones care must be taken that during switching on and operation of the pumps the pump section is filled with water (dry running) or alternatively is submerged or under water (wet installation). Ensure in this case that the minimum submergence given in the data sheet is observed. Other types of operation e.g. snore operation or dry running are not allowed.

Before commissioning the unit should be checked and a functional test carried out. Particular attention should be paid to the following:

- Have the electrical connections been carried out in accordance with regulations?
- Have the thermal sensors been connected?
- Is the seal monitoring device (where fitted) correctly installed?
- Is the motor overload switch correctly set?
- Have the power and control circuit cables been correctly fitted?
- Was the sump cleaned out?
- Have the inflow and outflows of the pump station been cleaned and checked?
- Is the direction of rotation correct - even if run via an emergency generator?
- Are the level controls functioning correctly?
- Are the required gates valves (where fitted) open?
- Do the non-return valves (where fitted) function easily?
- Have the hydraulics been vented in the case of dry installed pumps?

## 7 Maintenance



Before commencing any maintenance work the unit should be completely disconnected from the mains by a qualified person and care should be taken that it cannot be inadvertently switched back on.



When carrying out any repair or maintenance work, the safety regulations covering work in enclosed areas of sewage installations as well as good general technical practices should be followed.

**NOTE** *The maintenance hints given here are not designed for “do-it-yourself” repairs as special technical knowledge is required.*

**NOTE** *A maintenance contract with our works service department will guarantee you the best technical service under all circumstances.*



## 7.1 General maintenance hints

ABS submersible pumps are reliable quality products each being subjected to careful final inspection. Lubricated-for-life ball bearings together with monitoring devices ensure optimum pump reliability provided that the pump has been connected and operated in accordance with the operating instructions.

Should, nevertheless, a malfunction occur, do not improvise but ask your ABS customer service department for assistance.

This applies particularly if the pump is continually switched off by the current overload in the control panel, by the thermal sensors of the thermo-control system or by the seal monitoring system (DI). Regular inspection and care is recommended to ensure a long service life.

**NOTE**                    **The ABS service organisation would be pleased to advise you on any applications you may have and to assist you in solving your pumping problems.**

**NOTE**                    ***The ABS warranty conditions are only valid provided that any repair work has been carried out in ABS approved workshop and where original ABS spare parts have been used.***

## 7.2 Commentary on maintenance of lifting stations in accordance with EN 12056.

It is recommended that the lifting station be inspected monthly and its function checked.

In accordance with EN regulations, the lifting station should be maintained by a qualified person at the following intervals:

- in commercial premises - every three months.
- in apartment blocks - every six months.
- in a single family home - once a year.

In addition we recommend that a maintenance contract be taken out with a qualified company.

### 7.3 Oil filling and oil changing

The oil chamber between the motor and the hydraulic section has been filled at manufacture with lubricating oil.

AS Oil Fill Quantity - Oil Chamber							
AS 50 Hz					AS 60 Hz		
Pump Type		Litres			Pump Type		Litres
AS 0530	S12/2	0.48			AS 0530	S16/2	0.48
AS 0530	S17/2	0.48			AS 0530	S18/2	0.48
AS 0530	S26/2	0.48			AS 0530	S30/2	0.48
AS 0630	S10/4	0.56			AS 0630	S10/4	0.56
AS 0630	S13/4	0.56			AS 0630	S16/4	0.56
AS 0630	S22/4	0.56			AS 0630	S25/4	0.56
AS 0631	S12/2	0.48			AS 0631	S16/2	0.48
AS 0631	S17/2	0.48			AS 0631	S18/2	0.48
AS 0631	S30/2	0.48			AS 0631	S35/2	0.48
AS 0641	S30/2	0.48			AS 0641	S35/2	0.48
AS 0830	S10/4	0.56			AS 0830	S10/4	0.56
AS 0830	S13/4	0.56			AS 0830	S16/4	0.56
AS 0830	S22/4	0.56			AS 0830	S25/4	0.56
AS 0831	S22/4	0.56			AS 0831	S25/4	0.56
AS 0840	S12/2	0.48			AS 0840	S16/2	0.48
AS 0840	S17/2	0.48			AS 0840	S18/2	0.48
AS 0840	S26/2	0.48			AS 0840	S30/2	0.48
AS 0841	S13/4	0.56			AS 0841	S16/4	0.56
AS 0841	S22/4	0.56			AS 0841	S25/4	0.56

An oil change is only necessary if a fault occurs.



Repair work on explosion-proof submersible pumps may only be carried out by approved personnel in approved workshops.

When carrying out repairs only original spare parts, supplied by the manufacturer, should be used.

### 7.4 Cleaning

If the pump is used for transportable applications then it should be cleaned after each usage by pumping clear water in order to avoid deposits of dirt and encrustation. In the case of fixed installation, we recommend that the functioning of the automatic level control system be checked regularly. By switching the selection switch (switch setting "HAND") the sump will be emptied. If deposits of dirt are visible on the floats then these should be cleaned. After cleaning, the pump should be rinsed out with clear water and a number of automatic pumping cycles carried out.

### 7.5 Venting of the volute

After lowering the pump into a sump full of water, an air lock may occur in the volute and cause pumping problems. In this case, raise the pump in the medium and then lower it again. If necessary, repeat this venting procedure.



## EC Declaration of Conformity

**Manufacturer:** Cardo Production Wexford Ltd  
**Address:** Clonard Road, Wexford, Ireland

**Name and address of the person authorised to compile the technical file to the authorities on request:**

Frank Ennenbach,  
Director Product Safety and Regulations,  
Cardo Flow Solutions,  
Roskildevägen 1,  
Box 210,  
S-210 22 Malmö,  
Sweden.

**Declare under our sole responsibility that the products:** ABS submersible wastewater pump AS 0530 - 0841

**To which this declaration relates are in conformity with the following standards or other normative documents:**

As defined by Machinery Directive 2006/42/EC, EMC-Directive 2004/108/EC, Low Voltage Directive 2006/95/EC, ATEX 94/9/EC, Construction Products 89/106/EC



II 2G k Ex d IIB T4

**AS0530, 0630, 0631, 0641** = DIN EN 12050-2, EN 60335, EN 60079-0:2006, EN 60079-1: 2007, EN 13463-1:2009, EN 13463-8:2003, EN ISO 12100-1, EN ISO 12100-2, EN 809/A1, EN 61000-6

**AS0830, 0831, 0840, 0841** = DIN EN 12050-1, EN 60335, EN 60079-0:2006, EN 60079-1: 2007, EN 13463-1:2009, EN 13463-8:2003, EN ISO 12100-1, EN ISO 12100-2, EN 809/A1, EN 61000-6

Motor Type Examination BASEEFA 03ATEX0716X or BASEEFA 03ATEX0717X.

**Name / Address / Identification number of Notified Body:** Baseefa Ltd / Buxton, UK. / 1180.

17-11-2010

Sean Roche  
**Cardo Production Wexford Ltd.**

# SERVICE LOG

Pump Type:

Serial No:

Date

Hours of Operation

Comments

Sign

# SERVICE LOG

Date	Hours of Operation	Comments	Sign

# SERVICE LOG

Date	Hours of Operation	Comments	Sign

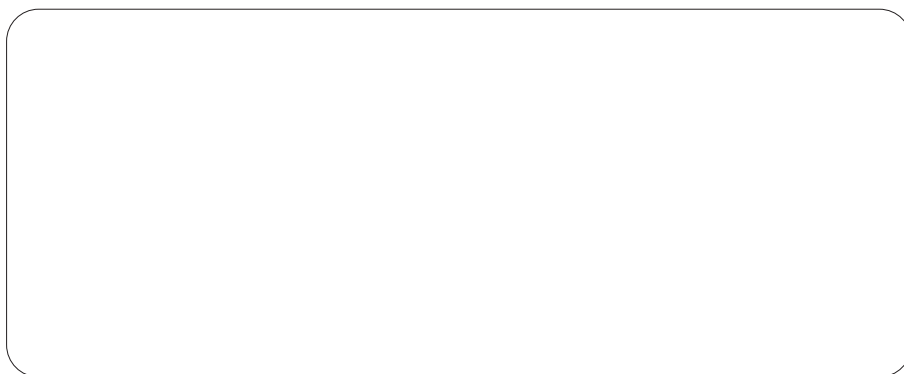

Cardo Production Wexford Ltd. Clonard Road, Wexford, Ireland  
Tel. +353 53 91 63 200 Fax +353 53 91 42335. [www.cardo.com](http://www.cardo.com)